

# SQUARE RISER BLOCKS

ITEM #A-15  
WEIGHT - SEE CHART BELOW

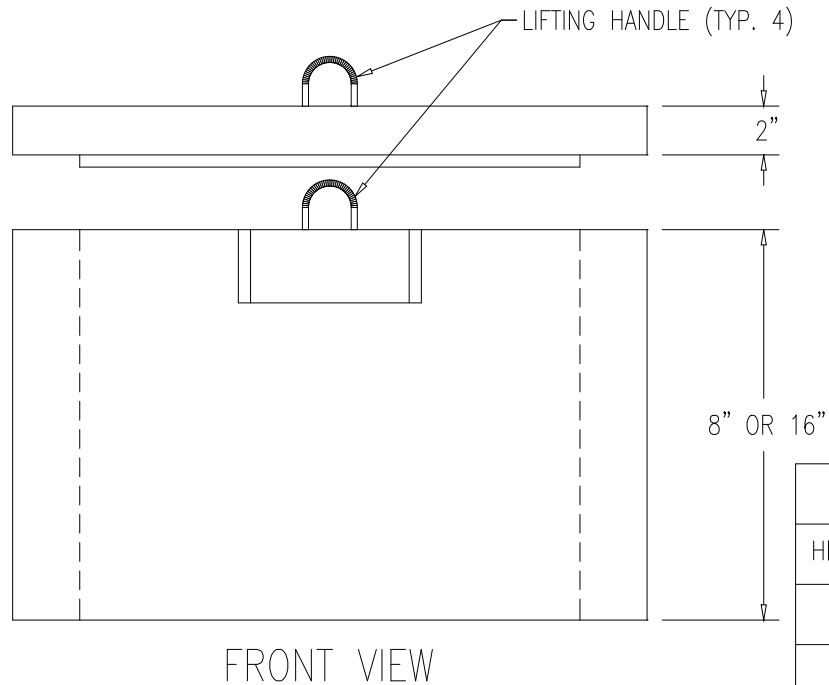
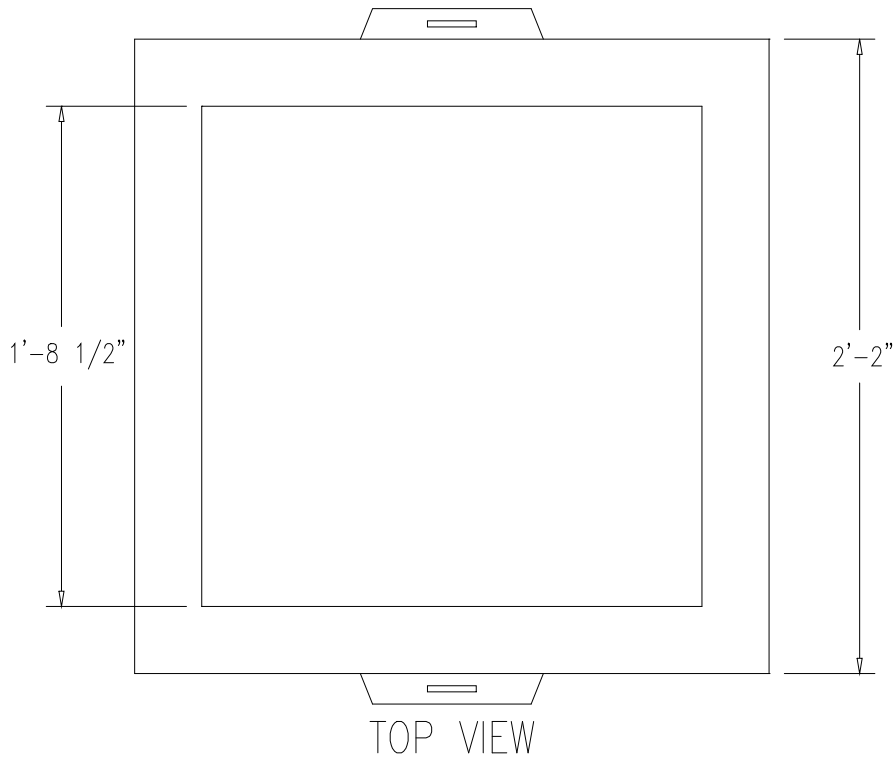

DESIGN NOTES:

- 1 - CONCRETE 4000 PSI AT 28 DAYS.
- 2 - THIS ITEM IS A STANDARD RISER FOR PUMP TANKS, LEACHING CHAMBERS, CHLORINE CONTACT CHAMBERS, AND WELL TILE COVERS.

RISERS		
HEIGHT	WEIGHT	ITEM #
8"	178 LBS	A-1501
16"	356 LBS	A-1502
COVER		
HEIGHT	WEIGHT	ITEM #
2"	120 LBS	A-15C