

COMBO TANK INSERT

ITEM #A-13A
WEIGHT - 1000 LBS

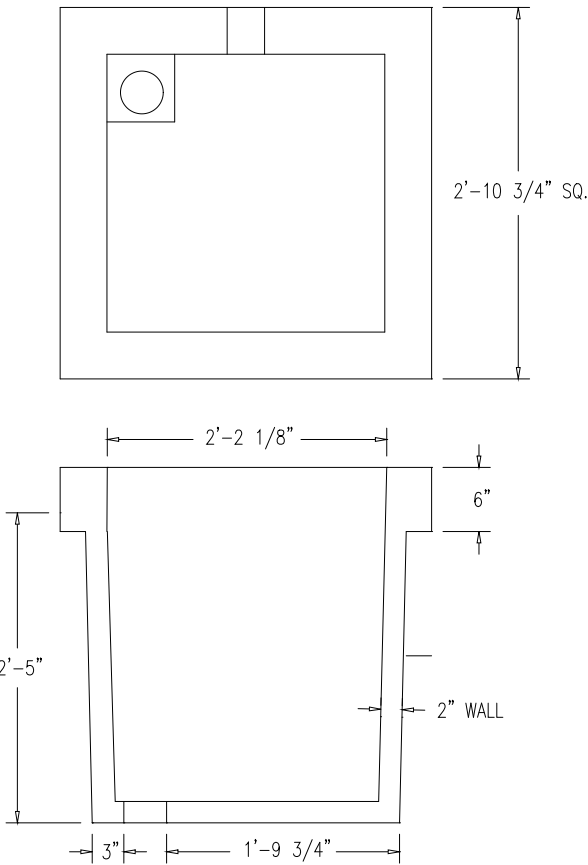

INSERT RISER & COVER

ITEM #A-13B
WEIGHT - 240 LBS

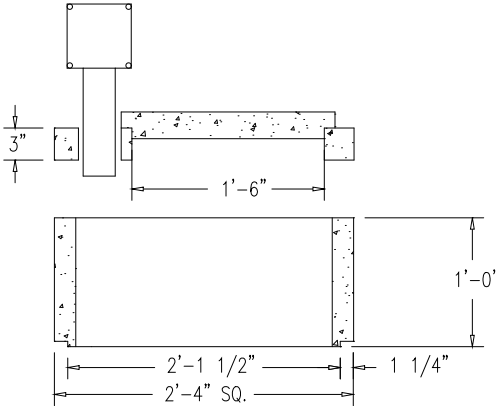

DESIGN NOTES:

- 1 - CONCRETE 4000 PSI AT 28 DAYS.
- 2 - REINFORCING WITH 6X6/10X10 W.W.M.