

3 HOLE D BOX

P/N: DBX3HOL  
 WEIGHT: 120LB  
 CY: 0.03CY

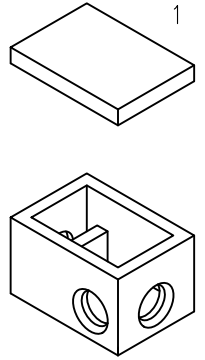

5 HOLE PUMP D BOX

P/N: DBPX5  
 WEIGHT: 120LB  
 CY: 0.03CY

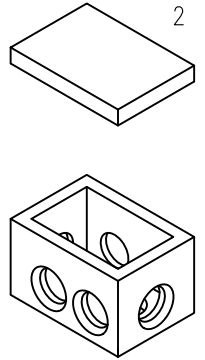

5 HOLE D BOX

P/N: DBX5HOL  
 WEIGHT: 120LB  
 CY: 0.03CY

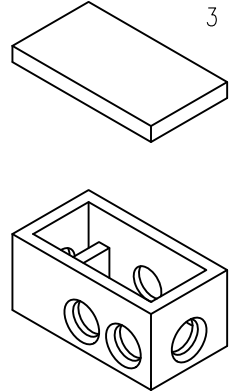

8 HOLE D BOX

P/N: DBX8HOL  
 WEIGHT: 200LB  
 CY: 0.05CY

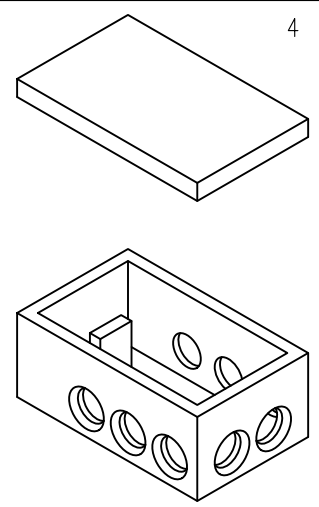

DESIGN NOTES

1. FIBER REINFORCED CONCRETE 5000 PSI AT 28 DAYS.



139 MAIN STREET, P.O. BOX 307  
 TOPSHAM, ME 04086  
 (207) 729-1628, FAX: (207) 729-8710

PRODUCT: DISTRIBUTION BOXES			
DATE: 12/7/20	SCALE: 1/2"=1'-0"	DRAWN BY: DTM	DRAWING NUMBER: SEE DETAILS