

4' DIA CONCENTRIC MANHOLE CONE

ITEM #C-4
WEIGHT - 2,000 LBS

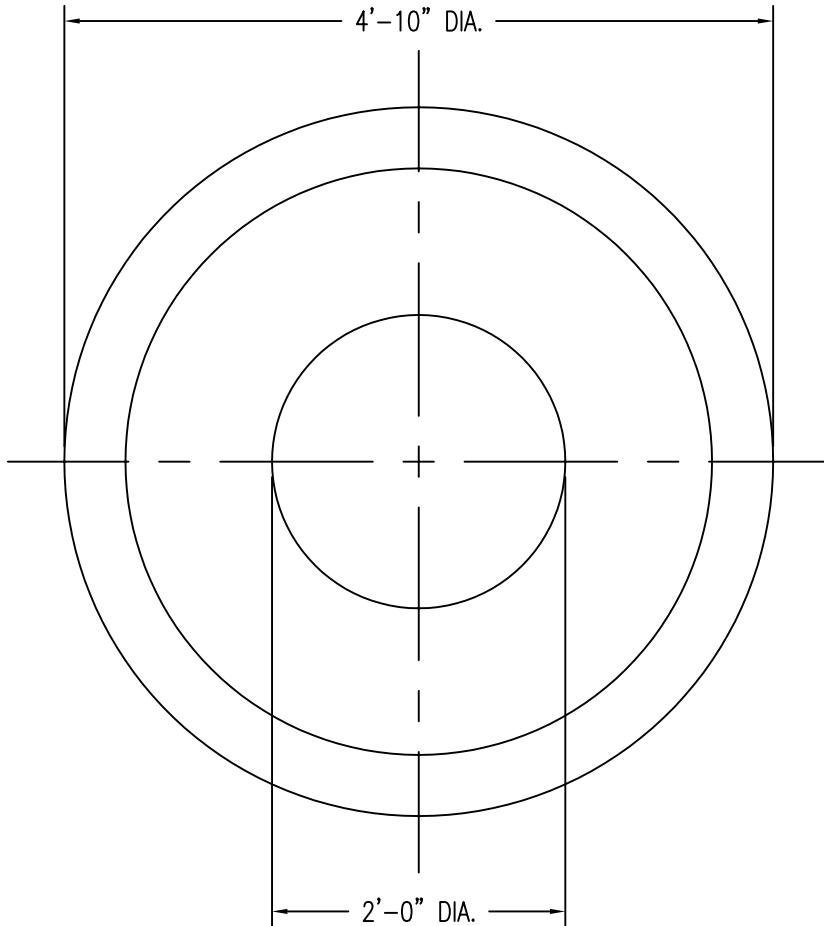

DESIGN NOTES:

- 1 - FIBER REINFORCED CONCRETE 4000 PSI
- AT 28 DAYS.
- 2 - DESIGNED TO CONFORM TO A.S.T.M. C-478.
- 3 - ALL MANHOLE MATERIAL MEETS H-20 LOADING REQUIREMENTS.

OPTIONS:

- 1 - DAMP PROOF EXT. COATING.
- 2 - CAST IRON FRAMES AND GRATES/COVERS.

